

# PCF Elettronica's NMH Mod. 529/NR Non-Methane Hydrocarbon Monitor

SHOWING  
AN EXCLUSIVE INJECTION SYSTEM,  
A PROPRIETARY AND EXCLUSIVE  
FLAME IONISATION DETECTOR,  
A COMPLETELY NEW SW PACKAGE



## Operating Manual

[Operating Manuals, ver. 2.0, SET. 11<sup>th</sup> 2019]



## Contents:

1.	Forewords	Pag. 3
1.1	Introduction	4
2.	Operating principle	5
3.	Technical Specifications	6
4.	Front Panel	8
5.	Rear Panel	10
6.	Inside view	12
6.1	FID Detector	14
6.2	Bimatic rotation valve	15
7.	Working mode	17
8.	Field commissioning and instrument start up	19
9.	In built firmware	21
9.1	Menu general description	21
9.2	HOME menu	22
10.	Analyser calibration	26
10.1	SPAN calibration procedure	26
10.2	ZERO calibration procedure	27
11.	Analyser maintenance procedure	28
11.1	Capillary flow rate check	29
11.2	Suggested maintenance schedule	31
11.3	Trouble shooting	32
12.	Serial communications and electrical connections	34
13.	Spare part list	36
14.	Factory final check records	38
	Appendix-1 Extract of FID response factors	40
	Appendix-2 Hydrogen safety	42
	Appendix-3	
A.3.1	Entering the SERVICE Menu	42
A.3.2	Resetting the front touch screen	42
A.3.3	Sucking capacity of air ejector	42



## 1. FOREWORDS

The FID detector is generally known as the most linear and stable sensor for detection of organic compounds. Particularly in environmental monitoring, where a mix of hydrocarbons are present in the sample, the measuring equipment requires a detector possibly equally sensitive to all types of compound.

The Non-Methane Hydrocarbon (NMH) analyser Mod. 529/NR, intended to operate both at room and high (120°C) temperatures, has been studied, developed and manufactured to monitor Total Hydro-Carbon (THC) Fraction, the Methane Fraction (CH<sub>4</sub>) and the difference between the two, namely the Non-Methane Hydrocarbon Fraction in ambient air and/or at emissions (Mod. 529/NRH).

Please note that NMH (Non-Methane Hydrocarbon) acronym is very much similar to commonly used TNMHC (Total Non-Methane Hydrocarbon). The basic difference is that our unit separates methane fraction by GC (Gas Chromatographic) column and the event is easily spotted, the other unit separates the CH<sub>4</sub> by catalytic combustion and the event is not displayable.

PCF Elettronica's FID detector is very well known for its stability as well as for its low maintenance in the time and easiness to be lighted.

It's generally known that organic compounds in hydrogen flame ionise. The quantity of carbon ions generated are proportional to the total quantity of carbon passing through the hydrogen flame. The FID detector is also defined as "atoms counter".

*The carbon (methane) equivalent concept.*

In the environment there is very high number of different organic compounds so the response of the instrument detector cannot be referred to a single compound. The measurements must be considered in terms of equivalent response, i.e. the response of the detector is "normalised" (referred to) to a single compound.

The characteristics of FID detector, i.e. approximately proportional to organic carbon concentration in the sample, makes the purpose easy. At first approximation the same concentration in air of compounds with different carbon atom number responds proportionally to the number of atoms in the molecule, so:

Concentration ppm	Species	FID response
1	CH <sub>4</sub>	1
1	C <sub>2</sub> H <sub>6</sub>	2
1	C <sub>3</sub> H <sub>8</sub>	3
1	C <sub>6</sub> H <sub>6</sub>	6

In other words, once the instrument response is *normalised to methane* (or carbon) *equivalent*, for example 1 ppm of propane will approximately generate a signal correspondent to 3 ppm of methane (actually the signal is not exactly three times but more likely 2.72 times).

For further info on the matter please check Appendix 1 at the end of the Operating Manual.

## 1.1 INTRODUCTION

The present manual includes the following sections:

- general description of the analyser component parts
- description of commissioning and start up procedure
- short description of firmware
- analyser basic maintenance procedure
- main trouble shooting.

The new in-built firmware that controls the analytical cycle is fully described in the HOME MENU.

The SERVICE MENU should not be entered but left to service purposes.

The operative functions, the status, the temperatures as well as the analytical data are managed by an industrial micro processor, while the analytical programs is permanently recorded on EEPROM.

The default instrument configuration as well as all the analysis may be recorded on a “digital pen” inserted in a dedicated USB port accessible from the front panel.



USB slot for flsh drive (“digital pen”)

Such instrument firmware allows data banking for all analytical data, these can be successively downloaded through the serial connection: RS 232-485 or Ethernet/LAN.

Up to six analogue signals 0-1/10 Vdc or  $\pm$ 4-20 mA (optional), relevant to the concentration of four components are available on the analogue output PCB for Mod. 529/NR NMH monitor just three of these analogue outputs are in use.

A LCD graphic digital display shows the analysis progress, the instrument operating status, the measured values, diagnostic data, alarms, that may be selected by the front panel key board, according the need and the variables of analytical program as well as the actual output of FID signal.



## 2.0 OPERATING PRINCIPLE

The PCF Elettronica's Mod. 529/NR NMH analyser detects and records Methane and Non-methane fractions of Hydrocarbon in a wide range of ambient conditions without any possibilities of water condensation or limitation in the ranges, from few tens of ppb up to hundreds of ppm.

The separation of Methane fraction from all other organic components is carried out by Gas Chromatographic (GC) column, each cycle of analysis includes two injections, the first to measure CH<sub>4</sub> after separation in a packed GC column, the second one to measure the Total VOC by direct injection of the sample into the FID. The NMH (Non-Methane HC) fraction is determined by the subtraction of the CH<sub>4</sub> concentration from the TVOC concentration. For this purpose, it is better to operate in terms of mg/m<sup>3</sup> instead of ppm. If necessary, the mg/m<sup>3</sup> may be converted into the ppm of the normalisation molecule (Propane, Butane, etc). The latter determination of NMH fraction with two separate injection guarantees an higher sensitivity (LDL) as well as the complete determination of TVOC even for very high boiling molecules.

*The instrument may also be configured for a single injection and direct measurement of NMH fraction after flush back of the column.*

The instrument can be either employed in automatic monitoring systems or in a transportable version for air quality monitoring.

The basic analytical cycle is capable to measure continuously TVOC/THC (Total Hydro Carbons, i.e. any type of hydrocarbon compound present in the environment), CH<sub>4</sub> (Methane fraction) and NMH (Non-Methane Hydrocarbons fraction), which actually is the difference (TVOC/THC - CH<sub>4</sub>). The full analytical cycle is calibrated through traceable gas cylinders.

The Flame Ionisation Detector (FID) is based on a hydrogen micro flame, where the organic compounds are oxidised and a correspondent number of ions are produced. The detector is therefore insensitive to the compounds structure and the generated ions quantity is just proportional to the carbon amounts present in the sample.

The actual procedure for the detection of carbon atoms in the sample foresees the mixing of the combustion hydrogen with the sample flow; this mixture is successively burnt in a micro flame with oxygen excess (hydrocarbon free air in large stoichiometric excess).

The electrical charges, generated by the combustion of the organic substances in gas sample are collected by two polarised metallic electrodes and converted in electrical current. Successively these ionisation micro-currents are converted in an electrical circuit into voltage drops directly proportional to the currents generated in the flame.

The values obtained by the above describe procedure are managed by the electronics then showed on a digital display as well as made available at the outputs as analogue signals for local or remote recording and control.

The same concentration values are available through the serial port, Ethernet/LAN port and, memorised on a digital pen, may be downloaded into a PC or any other digital Data Acquisition System.

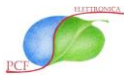

### 3.0 TECHNICAL SPECIFICATIONS

- Active range : 0-10,000 ppm ( $\text{mg}/\text{m}^3$ )
- Measuring ranges  $\text{CH}_4$ , THC, NMH : (four/six ranges 0- 10/20/50/100 ppm)  
(others available on request, within the active range)
- Units : ppm or  $\text{mg}/\text{m}^3$  (*better to operate in terms of  $\text{mg}/\text{m}^3$* )
- Background noise : 0,01 ppm
- Lower Detectable Limit (LDL) : < 0.02 ppm
- Zero stability (24 hours) : < 0.01 ppm
- Span drift (24 hours) : < 0.02 ppm
- Measuring cycle : 180 seconds
- Response time : 180 seconds
- Linearity : better than 1% full scale
- Precision :  $\pm 0.5 \%$
- Sample flow rate : 500 ml/min (*independent from response*)
- Operating temperature range : 0 - 40°C
- Display : 800 x 480 pixel touch screen colour LCD graphic display.
- Information on display : all the set working conditions of the instrument.
- Instrument configuration : from front panel, or from remote by Ethernet/LAN
- Three Analogue outputs
  - $\text{CH}_4$  : 0-1/10Vdc or 0/ 4-20 mA (optional)
  - TVOC : 0-1/10Vdc or 0/ 4-20 mA (optional)
  - NMH : 0-1/10Vdc or 0/ 4-20 mA (optional)
- Serial outputs : RS 232-485, (9 pin connector), Ethernet/LAN.
- Zero drift : automatic compensation
- Zero/Span : set from front panel and/or remote control.

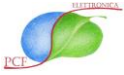

- Services
  - Hydrogen : 25-30 ml/min
  - Pure Air : 250-300 ml/min
  - Service Air : > 4.5 Bar (65 Psi), clean and dry, without HC
  
- Calibration gas cylinder : suggested, 4 ppm CH<sub>4</sub> + 1 ppm C<sub>3</sub>H<sub>8</sub> (propane), air balance (proportionally higher for ranges higher than 10 ppm).  
*Please note that, as the instrument measures in the second injection the TVOC, the latter in the calibration cylinder should not be higher than the selected range.*
  
- Sampling pump : WISA WIDO
- Mounting : standard 19" rack and/or transportable bench top
- Dimensions : 480x190x560 mm (19"x10"x22", WxHxD), 4U
- Weight : 15 Kg
- Standard power supply : 230/110 Vac 50/60 Hz (to be specified in order)
- Power consumption : ≈ 300 VA
- Pneumatic connections : 1/4" or 4/6 mm and 1/2 mm

## 4.0 FRONT PANEL DESCRIPTION



The front panel (see above figure) shows on the right-hand side the touch screen colour video graphic display, no more key board, the operating menu is user friendly, easy to select as well as correct the selection if needed.

The left-hand side magnetic closed door gives access to the gases controls as well as to the USB port for the digital pen.

As the instrument is fundamentally a very compact and simple gas chromatograph, the configuration of the same, namely NMH, BTEX and specific HC, is indicted on the video display at the switching ON of the instrument.

The touch screen is of the types mounted on modern phones and tablets, it must touched with the fingertips, no nails, pens or stick.



Access to the manometer set with relevant pressure reducers to allow the setting of instrument service gas pressures is allowed through a small door on the left hand side of the panel. Along with manometers and pressure reducers the gas chromatographic column by pass valve is also available (whenever needed).

The H<sub>2</sub> (hydrogen) manometer gauge, as combustible gas for the FID flame, is located on the right-hand side; the Air gauge (air to FID), as the combustion gas for the flame, stays in the middle and, finally, the Carrier (Pure Air) gas gauge, for the regulation of the carrier gas through the chromatographic column (whenever present) can be found on the left-hand side.

On top of each gauge a trimmer allows the regulation and setting of the gas pressures.

Please remember that:

**pressures/flows of gases (not for the sample flow rate) are strictly connected to FID response and therefore to calibration.**

Keep the setting of the pressures/flow as much constant as possible (take care to tag the set values in your installation), better if at the same value indicated in the FINAL CHECK RECORDS supplied with each instrument.

By opening the left-hand side door access to USB port for a digital pen slot is allowed, on the latter digital pen analytical data, instrument set up and analytical method, that supervises the automatic procedure of desired analysis. The digital pen can be extracted and easily read by any reading support connected to a PC.

The basic operating menu (HOME MENU) is displayed on the lower part of the video display. As said it is user friendly and allows easy correction, by back return, if some selection proved wrong.



**DISPLAY RUNNING BUTTONS LIST:**

- IGN: for the ignition of FID flame.
- AZERO: electrical zeroing of the FID signal.
- ZERO: ZERO command (the instrument enters ZERO at the end of running cycle).
- SPAN: SPAN command (the instrument enters SPAN at the end of running cycle).
- RANGE: select range of the instrument (usually 4 or 6 ranges freely selectable)
- START/STOP: Start and Stop “Monitor” running cycles. By pressing “Stop” the instrument stops working and enters into (STAND BY) READY condition.
- GRAPHS: the running chromatogram is displayed.
- : Main menu button

**ANALYSER STATUS:**

MONITOR: “Status of analyser”; measuring condition.

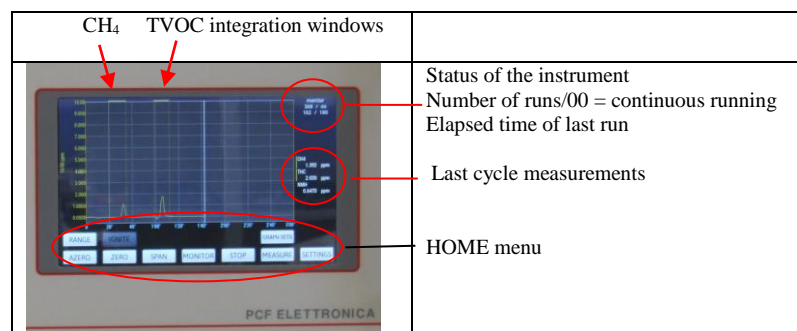

SETTINGS: the working sets and condition of the instrument may be modified while in operation (MONITOR), front end/back end feature.

## 5.0 REAR PANEL VIEW

### FRONT VIEW

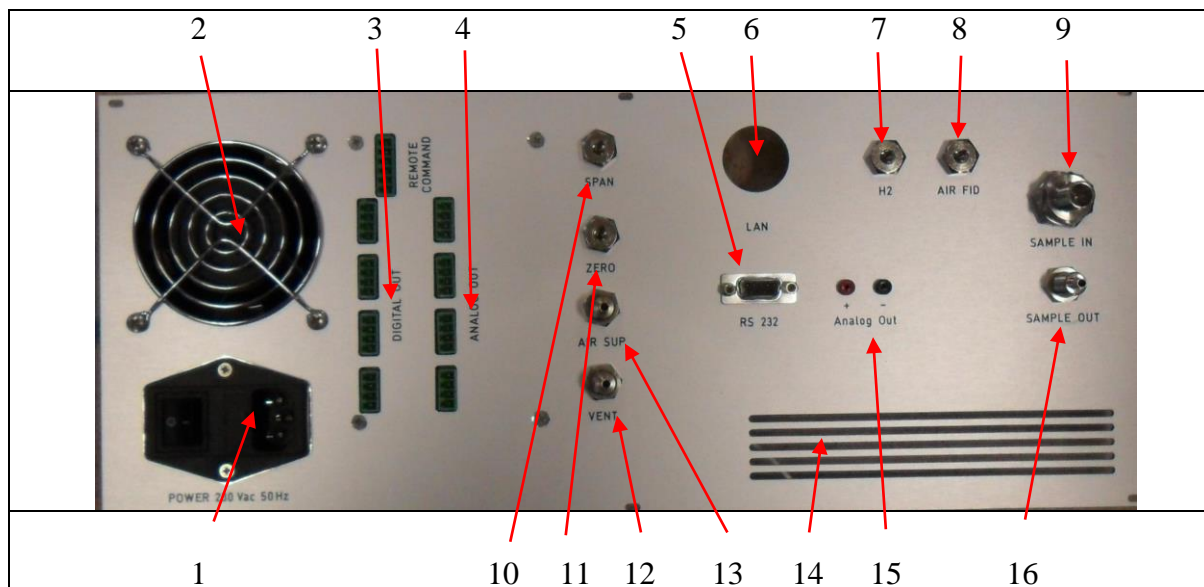

The rear panel (see figure above) includes the following items:

1. Input Power supply, 220/110 Vac, 50/60/Hz, 3-pin socket, with ON/OFF switch (1).
2. Cooling fan (2).
3. Instrument status and alarm output standard 25 pin male Cannon connectors (3).
4. Analogue signal output standard 13 pin female Cannon connectors (4).
5. RS-232/485 serial output, standard 9 pin female Cannon connector (5).
6. Ethernet/LAN, standard connector (6).
7. H<sub>2</sub>, input of hydrogen supply from U.P.P. gas cylinder or hydrogen generator, 1/2 tubes (7).
8. FID AIR, gas connection for FID air supply, for 1/2 tubes (8).
9. SAMPLE IN, gas connection 4/6 tubes of (14" Swagelock), for the sample gas input (9)
10. SPAN, gas connection, 1/2 tubes, for the calibration gas input (10)
11. ZERO gas connection, 1/2 tubes, For checking/calibrating zero (11)
12. VENT connection 1/2 tubes, of calibration gases (12)
13. Service AIR connection, 1/2 tubes, > 4.5 Bar (65 Psi) (13)
14. Ventilation grid (14)
15. FID analogue OUTPUT, 0-10 Vdc, directly from electrometer PCB (15).
16. VENT, gas connection, 1/2 tubes, for venting the sample gases (16).

## BACK VIEW

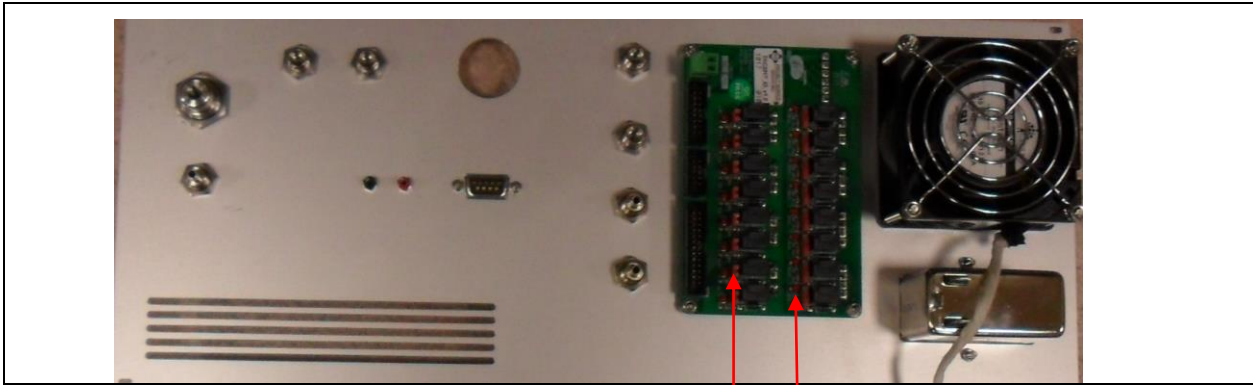

With red bridges on the output are in Vdc (selection 0-1/10 Vdc from front panel)

In the first versions of Mod. 529/NRs the selection for the 8 analogue outputs either in Vdc or mA is done via hardware with bridges on the reverse of back panel.

With the red bridges ON the analogue outputs are programmed for Vdc while with the red bridges OFF the analogue outputs are set for mA.

Once selected either Vdc or mA the ranges 0-1 Vdc or 0-10 Vdc are set from the front panel HOME menu.

The same for the analogue output 0-20 mA or 4-20 mA.

## 6.0 INSIDE VIEW

The great development in the field of integrated circuits, thanks to the use of very high integrated chips, has dramatically reduced the room occupied by electronics that manages all the instrument firmware. Inside the instrument we find the main Mother Board located on the right hand side, while the PCB carrying key board and LCD display is on the inner front panel, on the rear the PCB with all status and alarm signals, the analogue outputs and the connectors for remote connection.

The electrometer, the only electronic part that differs from the core electronics as it is a very high gain analogue amplifier, is located on the right hand side of equipment (as near as possible to FID detector).

The analysis chamber is the part that takes the largest room inside the instrument. It is located in the corner between the bottom and the left-hand side and takes half of the whole instrumental room. Within the chamber the whole analytical circuit, the chromatographic column, the sampling and gas flow rate control capillaries, the ten-port rotation valve as well as the FID detector are positioned.

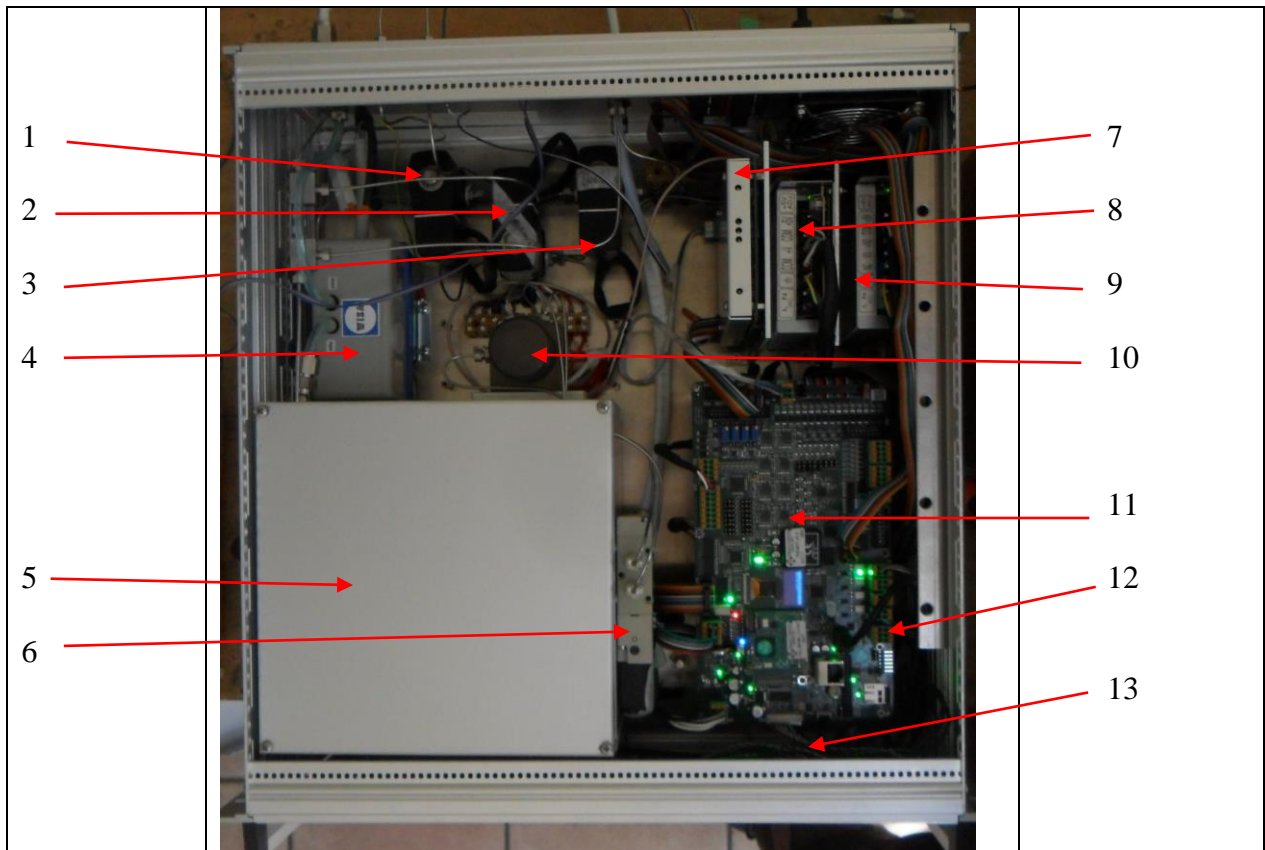

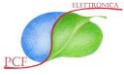
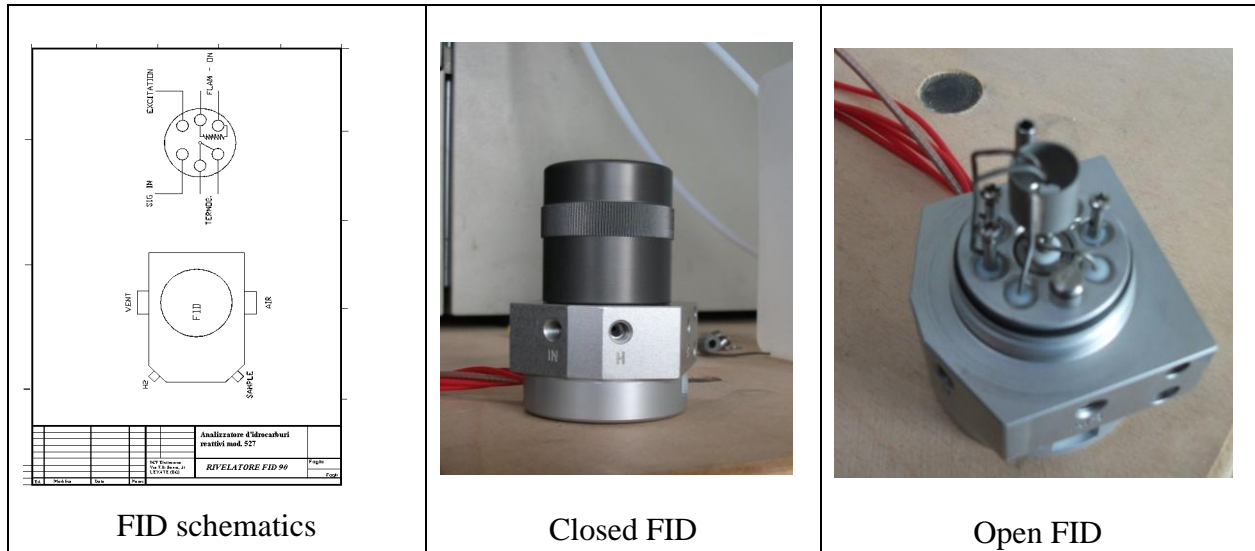

Figure captions:

- 1- H<sub>2</sub> interception Electro Valve (EV). The valve, fail safe type, intercepts/closes the hydrogen supply when the FID flame is OFF.
- 2- ZERO Electro Valve (EV). The instrument is intended, as default, to be zeroed with a Zero Air (ZA) gas cylinder. When activated the EV passes the Zero Air into the instrument. The excess of the Zero Air (ZA) is vented through the sample line. In case of calibration through a multipoint gas calibrator where the mixture is available at room temperature either the SAMPLE line or the SPAN line must be closed.
- 3- SPAN Electro Valve (EV). The instrument is intended, as default, to be calibrated with a traceable compressed gas mixture. When activated the EV passes the calibration gas mixture into the instrument. The excess of the calibration mixture is vented through the sample line. In case of calibration through a multipoint gas calibrator where the mixture is available at room temperature either the SAMPLE line or the SPAN line must be closed.
- 4- Sampling pump. The flow rate into the instrument is not related to the instrument response. The function of the sampling pump is just to keep the sample loop updated.
- 5- Temperature controlled gas chromatographic chamber.
- 6- Rotation valve (RV) electrical pilot valve (PV).
- 7- Electrometer PCB, with metal shield to avoid electrical interferences.
- 8- Power supply PCB, 220 Vac +5 Vdc, +24 Vdc.
- 9- Power supply PCB, 220 Vac +5 Vdc, +15Vdc, -15Vdc.
- 10- FID (Flame Ionisation Detector).
- 11- Main PCB.
- 12- Auxiliary PCB, under the Main PCB.
- 13- Touch screen LCD Colour Display

## 6.1 FLAME IONISATION DETECTOR (FID)



The FID, *Atom Counter*, is the core of the NMH analyser.

It shows a central nozzle that receives through a capillary hydrogen, about 25-30 ml/min, again through a capillary the nozzle is reached by the carrier gas carrying the sample compounds. The nozzle is polarised, from an external power supply by a positive voltage of 300 Vdc with very low electrical currents. A metallic ring on the top of the nozzle collect the ionisation current and takes it to the input of electrometer circuit. An air flow rate of about 230-3 ml/min, controlled by a third capillary, is supplied to the detector as combustion gas. The quality of the combustion air must be very good (carbon content lower than 0.1 ppm) and stable in the time, with the risk of jeopardising the measurements qualities.

Inside the detector are further located a Nickel spiral for the automatic switching of the flame as well as a thermocouple that detects when the flame is ON or OFF therefore command the automatic switching off the hydrogen flow when the flame is OUT.

The amplified FID electrical signal may be measured and/or recorded on strip chart recorder (normalised 0-10 Vdc signal).

## 6.2 BIMATIC ROTATION VALVE

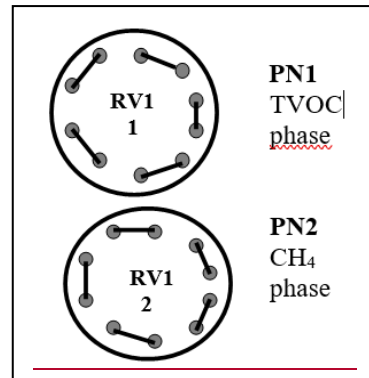
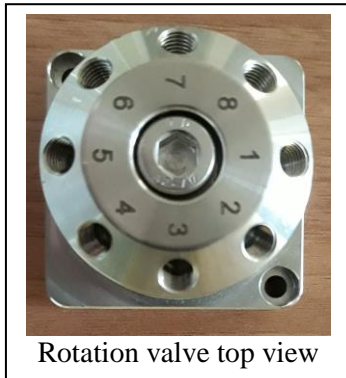

The installed one is a ten port rotation valve that connects all the pneumatic circuits. The switching of the valve is controlled by compressed air supplied through a four-way command solenoid valve. This valve allows the interconnection of other pneumatic circuits. In the Mod. 529/NR NMH analyser a single rotation valve provides sampling of gas as well as THC and CH<sub>4</sub> phase analysis.

In the pneumatic schematics the two different switching modes of the valve, i.e with the solenoid valve PN1 and PN2 for the relevant THC and CH<sub>4</sub> analysis phases, are shown. The ten-port rotation valve is conventionally indicated by RV1.

### Phase 1 “Analysis CH<sub>4</sub> and Sampling TVOC/THC”

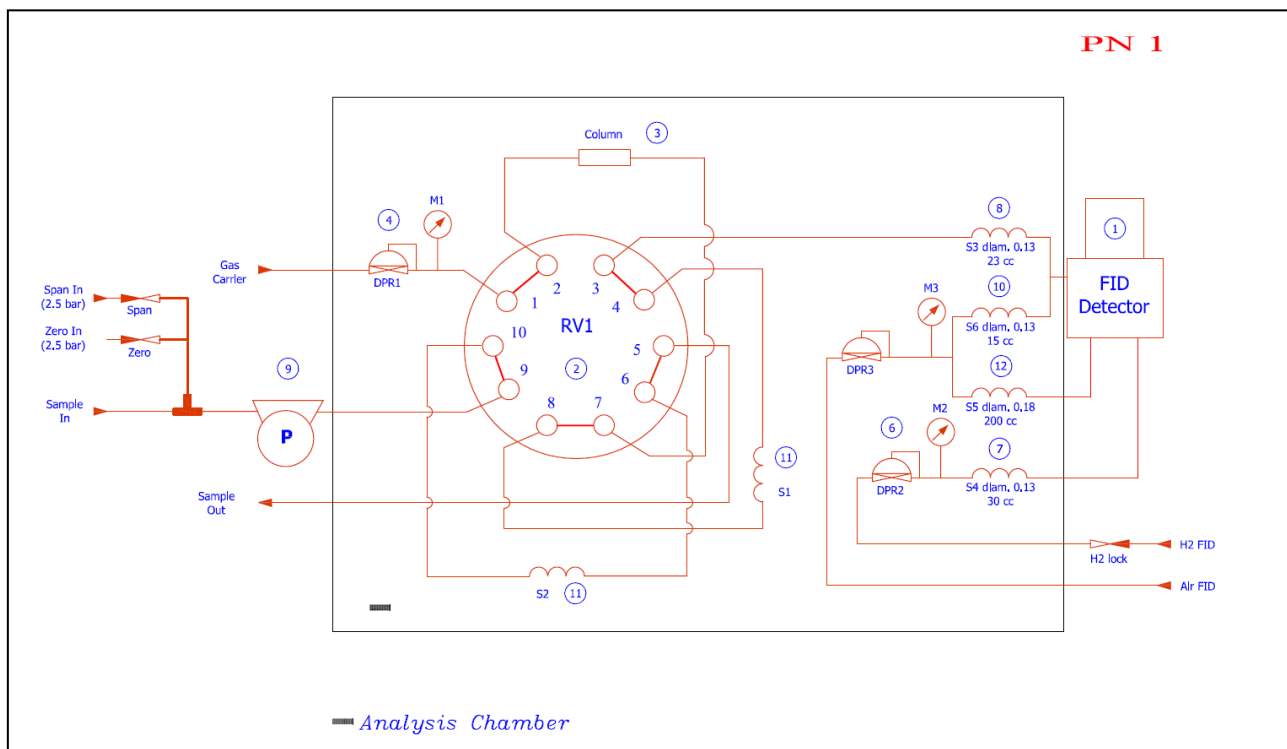

**Phase 2 “Analysis TVOC/THC and column Back Flush”**

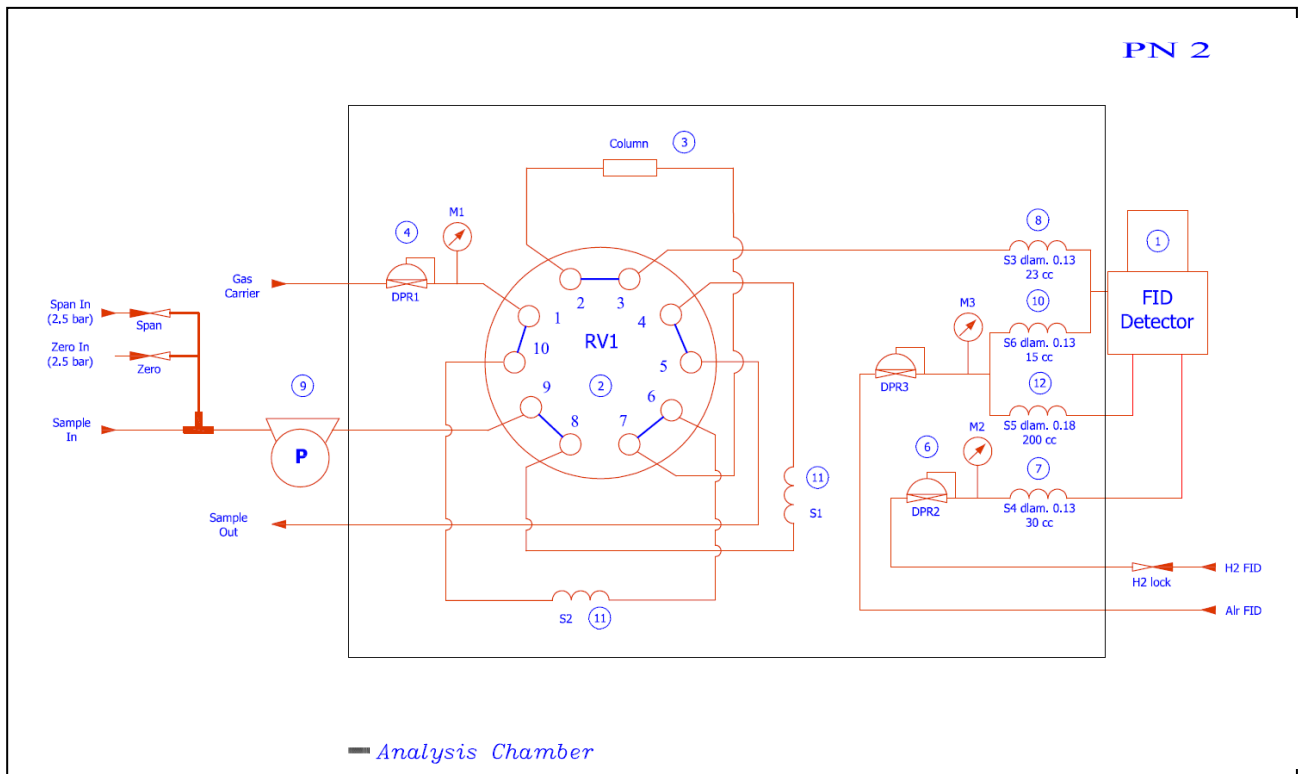

Figure Captions:-

- 1- FID detector
- 2- RV1 rotation valve
- 3- Gas chromatographic column
- 4- DPR1 CARRIER pressure regulator, M1 relevant manometer
- 5- DPR3 AIR (UPP) pressure regulator, M3 relevant manometer
- 6- DPR2 H<sub>2</sub> pressure regulator, M2 relevant manometer
- 7- S4 hydrogen capillary
- 8- S6 carrier gas capillary
- 9- Membrane sampling pump
- 10- S3 O<sub>2</sub> plus gas capillary
- 11- S2 (CH<sub>4</sub>) and S1 (TVOC/THC) sampling loop capillary
- 12- S5 air capillary

## 7.0- WORKING MODE

In working conditions, position PN2, gas sample is pulled by membrane pump P (9) or an air ejector, it passes through the sintered filter F1 (8) and then through the sampling loop S1 (11) with a capacity of 0.6 ml. Meanwhile the carrier gas controlled and displayed by the AIR CARRIER manometer on the instrument front panel goes through loop S2 (11) and the column then to the FID detector.

At the start of the cycle, the sampling pump is OFF to allow that the amount of sample in loop S1 is equilibrated against the atmospheric pressure, then the Bi-matic type rotation valve RV1 (F9) switches into position 1 (PH1) and the carrier gas flows into loop S1 taking the sample into the column and then into the detector.

While the compounds in the sample of loop S1 separate in the chromatographic column, the pump switches ON again and pulls the sample through loop S2.

The fastest compound through the column and the first to be detected by FID is the methane, the relevant signal is processed by the microcomputer and memorised in CH<sub>4</sub> electronic channel.

The pump switches OFF again, the RV1 valve commutes to position 2 (PH2), carrier gas enters into S2 and takes the sample directly into the detector generating a signal proportional to the total quantity of hydrocarbons present in the sample. The whole amount of hydrocarbons dissolved in the sample are determined with no possibility of queuing effect of water interference, as it may occur in other analysers.

The relevant signal is processed by the microcomputer and memorised in the THC channel as the Total Hydro-Carbon value.

For the whole time RV1 is in position PH2 the chromatographic column is under a back flush current that brings out all the heavy compounds injected with CH<sub>4</sub> fraction.

The analytical cycle can be summarised as:

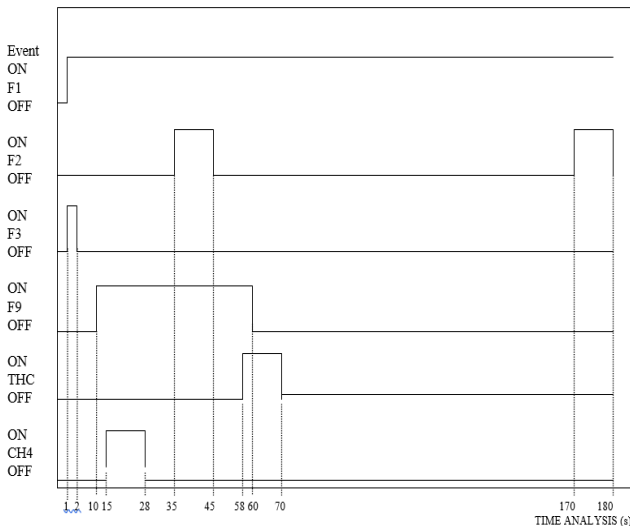

The relevant Electrometer (0 -10 V range) output will be:

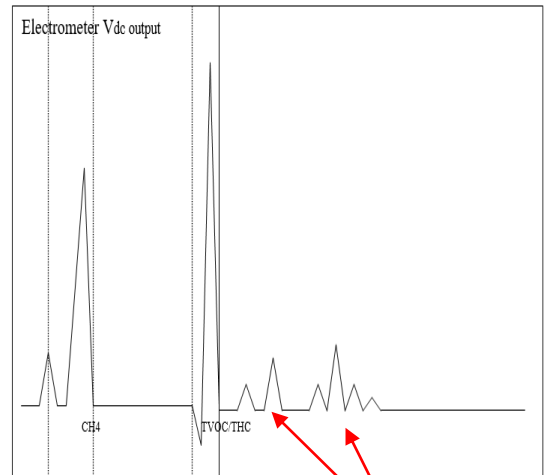

Back flush of GC column.  
In calibration phase there will be a single broad peak

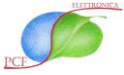

The three analogue signals, i.e TVOC/THC, CH<sub>4</sub> and NMH [0-1/10 Vdc or 0/4-20 mA (optional)], are available on the output connector (see rear panel).

The table of operative conditions as well of the values is enclosed in the manual as final check.

The length of analytical cycle is programmable according to the needs connected to the application; the above described one lasts 180 seconds.

After 180 seconds the analyser is ready to repeat the same cycle, more cycles or continuous operation according to the operator choice.

- "**ZERO**" check is performed by introducing a sample totally free of carbon compounds (carbon content lower than 0.1 ppm).

As a carrier gas is employed ultra pure AIR (an air with the content of carbon compound lower than 0.1 ppm), it is not required to introduce further air to check the ZERO, it's enough to keep the pump OFF, this operation introduces just U.P.P. carrier air filling the loops S1 and S2 respectively, free from any interference from external sample.

- "**SPAN**" Calibration/Check is performed by introducing in the circuit, by the activation of a special solenoid valve, the content of a gas cylinder of known concentration and repeating the described cycle operations. By operating on the key board, on the electronic regulators controlled by micro computer the sensitivity of the instrument can be adjusted (ADJ); the set sensitivity values are then memorised.

**Please remember** that whenever the combustion and carrier gas air is not HC free (CH<sub>4</sub> is the species most difficult to scrub) the response for CH<sub>4</sub> content decreases.

Please take into account that CH<sub>4</sub> content is always around ~2 ppm, slightly higher in agricultural and polluted -environment. Whenever you do not find these values you must check efficiency of you HC high temperature scrubber.

The versatility of user friendly firmware both from the analytical point of view and the program configuration, allows, by choosing the suitable chromatographic column and the relevant software program to detect specific compounds both in air quality monitoring and at emissions. This is a great advantage with respect to the instrumentation actually available on the market.

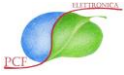

## 8.0 FIELD COMMISSIONING AND INSTRUMENT START UP

- Connect the plumbing between the cylinder gas pressure reducers and the relevant gas connectors located on the analyser rear panel and indicated as Hydrogen, FID air, Air Sup(ply).
- Connect the power cord to the main power supply (220/110 Vac, 50/60 Hz, 300 VA).
- Open the cylinder interception valves and regulate the relevant output pressure from cylinders as follows:  
FID pure Air  $\approx$  3 Bar (43.5 psi),  
Hydrogen  $\approx$  3 Bar (43.5 psi),  
if for the servo commands a separated compress air is used, regulate it to  $>$  4.5 Bar (65.25 psi).
- The relevant pressure on the manometers located on the instrument front panel, instead, must be set according to the values indicated in the instrument final check card, that goes with each instrument. Please note that the pressure of H<sub>2</sub> is only visible in the condition of FLAME ON or the IGNITE icon pressed.
- Switch the Power switch, on the rear panel of the instrument, in to position ON (indication I), now the instrument is ON, the display is ON, the start up procedure is running and the home display is on the screen.
- As the instrument reaches the temperature set it starts the control of FLAME ON, if the flame is off the FLAME OFF condition is displayed.
- In the status of FLAME OFF press IGNITE icon button, set the hydrogen pressure to the value indicated in the final check record. Wait about 20-30 seconds.
- When FID flame in ON, the instrument enters into the STAND-BY mode and no flame alarm I displayed on the screen.
- In case the flame of FID does not ignite, the instrument automatically shows on the display an alarm of FLAME OFF accompanied by a chime sound. In these conditions the flame is off. Repeat the operation described above to reach the FLAME ON condition ("STAND-BY" will be on the screen).
- If on the display any alarm messages are shown, as long as all alarm conditions are not erased the indication "STAND-BY" will not be displayed.  
*NOTE: in occasional conditions, it is necessary to reduce drastically the carrier gas pressure to switch on the flame.*
- Once the flame is ON wait for 10-15 minutes then take the Sample (Carrier) manometer to pressure set written in the enclosed final check record.
- Wait further 5 minutes then press the icon button AZERO (Autozero).

## Different field commissioning of Mod. 529/NR, NMH analyser

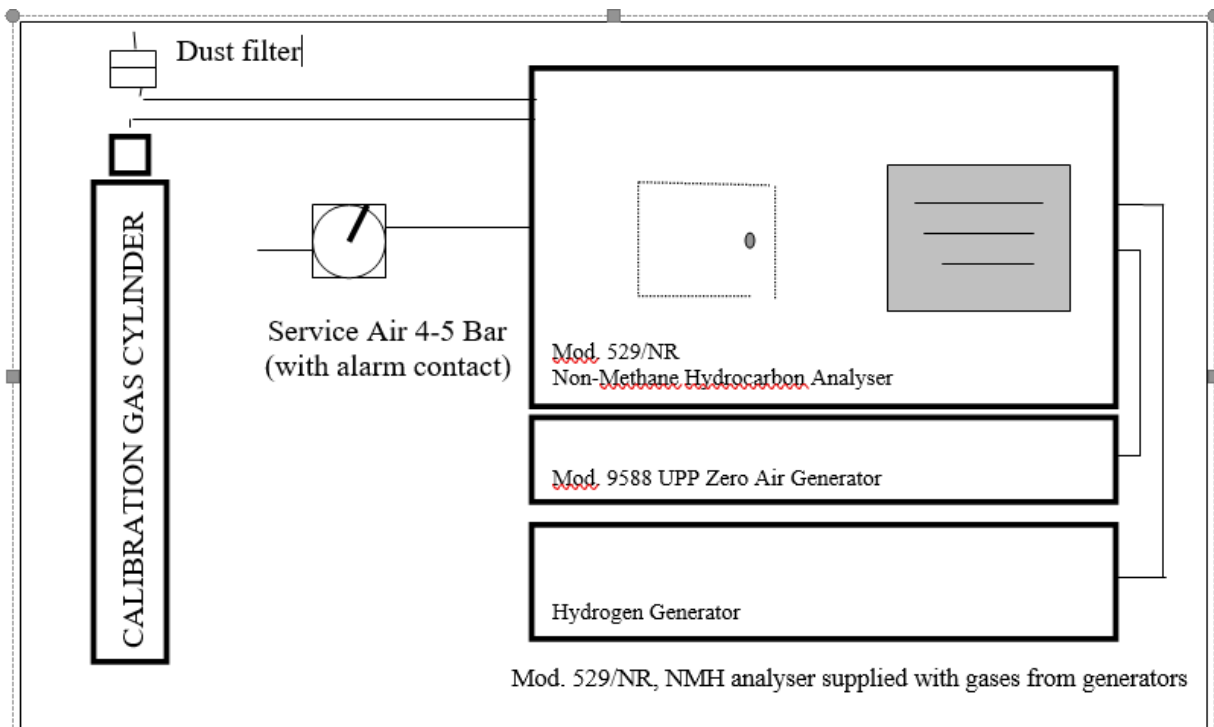
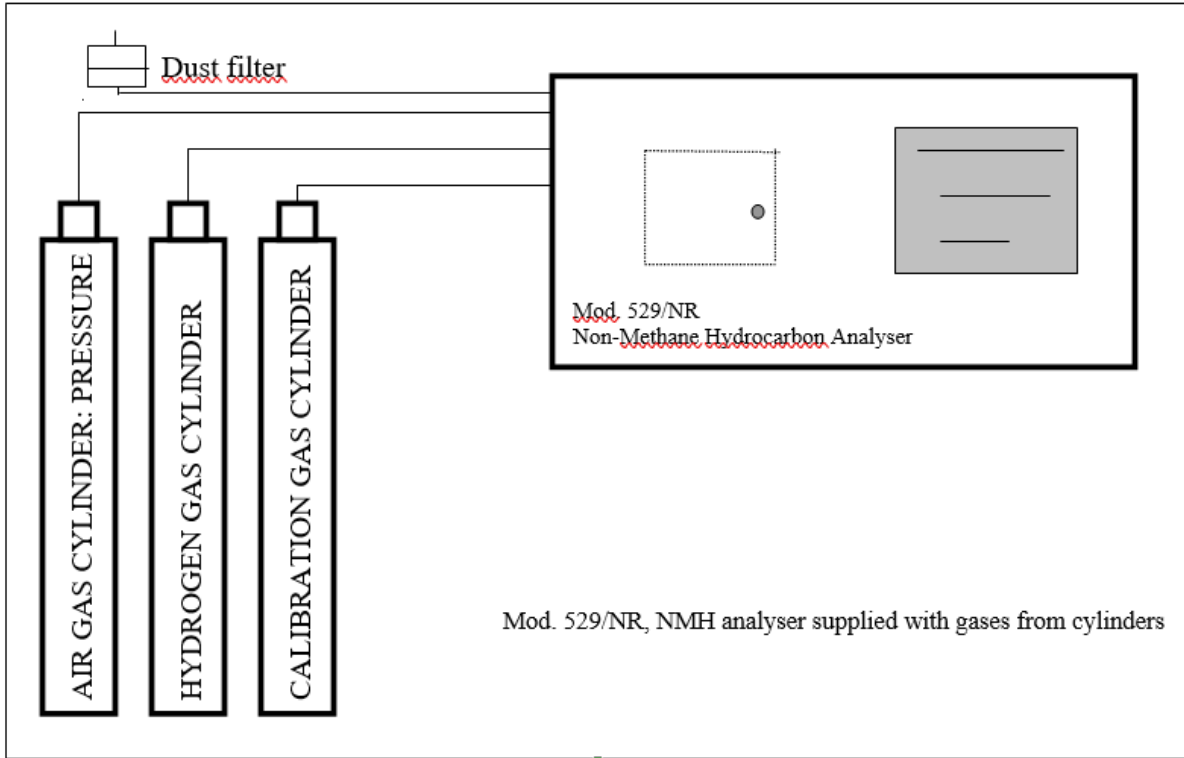



## 9.0 IN BUILT FIRMWARE

(Do not enter the service menu unless necessary)

At the switching ON, after a few seconds the front page (HOME PAGE) is displayed.

RANGE:	select range of the instrument (usually 4 or 6 ranges freely selectable)
IGNITE:	for the ignition of FID flame.
DIAGNOSTICS:	information on working set and conditions.
AZERO:	electronical zeroing of the FID signal.
ZERO:	ZERO command (the instrument enters ZERO at the end of running cycle).
SPAN:	SPAN command (the instrument enters SPAN at the end of running cycle).
MONITOR:	measuring condition.
STOP:	the instrument stops working and enters into STAND BY condition.
GRAPHS:	the running chromatogram is displayed.
SETTINGS:	the working sets and conditions of the instrument may be modified while in operation (MONITOR), <i>front end/back end feature</i> .





### 9.1 MENU GENERAL DESCRIPTION





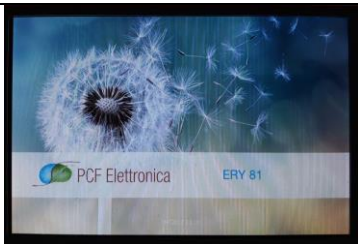
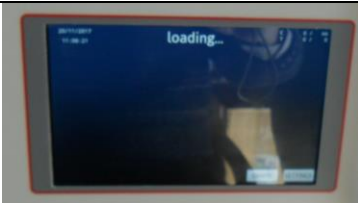

As previously said, the basic instrument menu is self-explaining, user friendly menu. With simple information the operator may carry out the fundamental operation on the instrument:







- i) Start the instrument operation (MONITOR icon).
- ii) Check/Calibrate ZERO
- iii) Check/Calibrate SPAN.
- iv) Modify the instrument basic configurations, excluded the modifications done only in the service menu.
- v) Some important information to note:
  - 1- Whenever you open a window from the HOME menu you always may return BACK without recording the possible modifications.
  - 2- When the instrument is switched ON and starts warming up, he reads automatically the default configuration from the USB port (see picture ...) provided that the digital pen with the default configuration is inserted in the USB slot.
  - 3- The New Software is of the type . It means that the operator may dialogue with the electronics while the cycle is carried on.



## 9.2 HOME MENU

Let' see step by step what happens when you switch ON the instrument.

STEP	DESCRIPTION	PICTURE
1	<p>At switching ON the instrument shows the PCF's LOGO.</p> <p>The Model Number of the unit in operation is displayed. Remember that the same electronics may be configured for Mod. 529/NR NMH, 530NR BTEX and for Specific Compounds (e.g. AROMATICS)</p>	
2	<p>The instrument reads the default configuration from the USB port.</p>	
3	<p>The instrument warms up. No monitoring in this phase. Please note that on the bottom lines of the display the basic icons are displayed.</p>	
4	<p>The instrument concluded the warm up phase, note that the temperature of the analytical temperature reached the set value (left-hand, middle of the screen) The SW informs the operator that the FID flame is OFF.</p> <p>If the switching ON of the flame is programmed as automatic the instrument will switch on the same otherwise the operator must switch it on by touching IGNITE icon.</p>	
5	<p>The instrument is telling that it tries to switch ON the flame. Please note that it will do three trials. If they are unsuccessful an alarm will be shown. The first time the ignition of the flame could be difficult because there is air in the H2 tubes. We suggest to purge the H2 tube before starting the igniting of the instrument.</p>	

<p>6</p>	<p>The SW tells that it is ready to:</p> <ul style="list-style-type: none"> <li>- Start the cycle (MONITOR icon)</li> <li>- Check/Calibrate ZERO</li> <li>- Check/Calibrate SPAN (the range)</li> </ul>	
<p>7</p>	<p>The operator has chosen MONITOR. The instrument enters in monitoring (measuring) phase. Do not bother about the absolute values. As the instrument was opened and set different times the first analysis will not be reliable.</p>	
<p>8</p>	<p>This is the video display when the operator chooses SETTING icon. All the simple settings of the instrument are displayed. The more advanced settings are reachable from the Service Menu. Note that whenever you open an icon you have three choices:</p> <ul style="list-style-type: none"> <li>- To return back to the previous step.</li> <li>- To return to HOME display.</li> <li>- To save the introduced modifications.</li> </ul>	
<p>9</p>	<p>Once the IGNITE icon was touched the operator may choose to ignite the flame</p> <ul style="list-style-type: none"> <li>- Automatically: auto-ignition tipped off</li> <li>- Manually, auto-ignition <b>not</b> tipped off</li> <li>- Switch OFF the flame.</li> </ul>	
<p>10</p>	<p>Whenever the operator did not save the set modification.</p>	
<p>11</p>	<p>RANGE, to choose the measuring range as default one. The instrument may be programmed for up to 6 ranges: from 0-5 mg/m<sup>3</sup> up to 0-10,000 mg/m<sup>3</sup></p>	

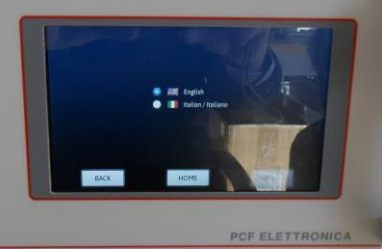
12	TEMPERATURE, the setting of the temperature controlled chamber temperature.	
13	CALIBRATION, for setting the calibration reference values.	
14	ANALYSIS PROGRAM (CYCLES), to set the number of measuring cycles. When setting 00, the instrument measures continuously for infinite cycles. Till STOP Is selected.	
15	DATE AND TIME, to set the correct date and time.	
16	IP ADDRESS, setting of the instrument identification code.	
17	DIAGNOSTIC, it shows the working conditions of the instrument. No setting possible.	

18	LANGUAGE selection.	
19	OPTIONS, further setting of the instrument operating mode.	
20	<p>SERVICE, the way to enter into the service menu Is protected by a password. <b>Do not enter unless strictly necessary.</b></p>	

## 10.0 ANALYSER CALIBRATION

Whenever either a *check of* or a *full calibration* is required the instrument must be in the analysis mode. Only with the instrument in analysis mode the "SPAN" and "ZERO" function can be activated.

In order to start these procedures, the relevant icons must be selected on the lower part of the screen by moving around with arrow push buttons.

If the "ZERO" or "SPAN" icon is selected *the instrument performs the given command at the end of the current analysis cycle.*

*Please note that, as the instrument measures with the second injection the TVOC, the latter in the calibration cylinder should not be higher than the selected range.*

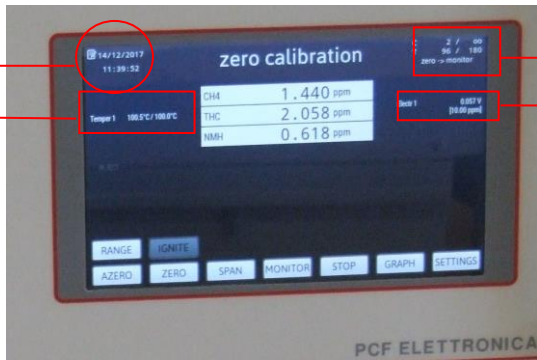
	Please read carefully the display you will find the fundamental working conditions of the instrument	
<p>Date and time</p> <p>GC chamber temperature (present and set one)</p>		<p>Cycle number/00 (continuous) Elapsed time After ZERO it returns to MONITOR</p> <p>Electrometer output Vdc Selected measuring range</p>

When the instrument is in "READY" condition it is like in a stand by conditions, waiting for next command.

Always press MONITOR button to resume the monitoring cycle.

*Always keep in mind that the instrument is working per cycles, therefore after any command you must wait till the instrument concluded the previous operation.*

### 10.1 "SPAN" CALIBRATION PROCEDURE

The instrument is on line; it is working regularly on sample gas.

- 1- Connect to "SPAN", on the rear panel of the instrument, the calibration gas source, namely gas cylinder, permeation tube or multipoint calibrator.
- 2- Open the valve of calibration gas cylinder and check/regulate a flow of 20-40 ml/min that is getting out of "VENT" output on the rear panel of the instrument.
- 3- From front panel display select "SPAN" procedure, by touching the icon on the screen.  
At the end of running analytical cycle the instrument enters the calibration procedure and start a new analytical cycle.
- 4- Select the correct measuring range to cover calibration concentration values by relevant push button.
- 5- Follow the indications and requests from the in-built SW. All the steps are self-explaining.

- 6- Operator must wait 3-5 full analysis cycles. Then the instrument will ask if the operator intends to carry out a full calibration.
- 7- Once the calibration was performed press MONITOR icon and the instrument returns to monitoring conditions after the end of running cycle. The calibration gas source can be closed.

Example:

Gas cylinders contains 4 ppm of CH<sub>4</sub> and 1 ppm of C<sub>3</sub>H<sub>8</sub>, air balance.

The THC equivalent, normalised against methane is (4+3) = 7 ppm.

By the above calculation we normalised all measurements taking methane as reference molecule.

The suitable range can either be 10 or 20 ppm full scale

*NOTE:* do not go with the amplification value lower than 01.00 as it would mean a gain factor lower than 1.

At the end of calibration procedure shut the calibration gas cylinder.

## 10.2 "ZERO" CALIBRATION PROCEDURE

Select the "ZERO" check procedure; once the instrument carries out the current analysis cycle, with the new analytical cycle the instrument enters into "ZERO" mode.

The "ZERO" mode consist in a certain number of analysis in "Blank", i.e. a UPP air is introduced into the chromatographic column, that exactly the same air used as carrier in order to evaluate the base line behaviour with no sample in the instrument.

The "ZERO" regulation on the present type of chromatograph does not make sense, as the auto zero function carries out an instrumental zero before any analysis.

## 10.3 ZERO/SPAN CHECK

FID detector is a very stable detector in the time.

Provided you keep the gas supply pressures and flows constant you will get a constant response of the instrument.

Instead of performing a full calibration of the instrument, with adjustment of response factors, you may just check the status of calibration of the same.

For this matter please carry our just a calibration check:

- 1- supply on the sample line either a zero or calibration mixture under vented conditions.

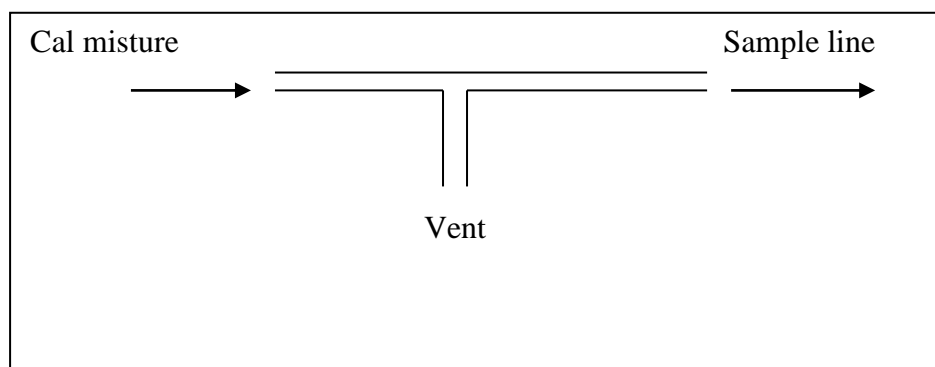

- 2- Check the response of the instrument, if it's within 5% of full scale do not modify the response factors.

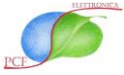

## 11.0 ANALYSER MAINTENANCE PROCEDURE

(CONCISE INFORMATION, EXTENSIVE INFO IN THE SERVICE MANUAL)

All the operations described in the present section must be performed with main power supply to the instrument OFF (disconnect the mains plug) and with the H<sub>2</sub>, Air, Span, Service gases intercepted by the main manometers on the gas cylinders.

*Please remember that whenever you take a step in the maintenance of the instrument be sure you will be able to return back in the original conditions.*

### REPLACEMENT OF INPUT SILICA WOOL FILTER (Whenever is present in the analyser)

- Open the measuring chamber. If the instrument is just switched off wait for the cooling down to about room temperature.
- With an 8-mm spanner disconnect the silica wool holder "F" inserted between the "sample-in" connection and the "U2" SPAN solenoid valve.
- Open the filter holder by employing two 17 mm spanner; either replace the steel sintered filter or wash it in a ultrasonic bath with a solvent at 80°C. Mount back everything with great care taking special care to the tightness of the pneumatic connections.
- Open the measuring chamber. If the instrument is just switched off wait for the cooling down to about room temperature.
- Bring the analyser into measuring mode (again following the standard procedures previously described in this manual) and leave the instrument to work for about an hour without performing any setting.
- Perform a calibration check and eventually adjust the Calibration values. ....

## 11.1 CAPILLARY FLOW RATE CHECK

The check of capillary flow rate is a very delicate operation; therefore, it must be performed with the maximum care and attention.

The Capillary flow rate check is performed with the instrument ON and all the service gases connected and pressurised.

Please refer to the following picture to locate the right places where to check the flows rate

### Controlled temperature chamber

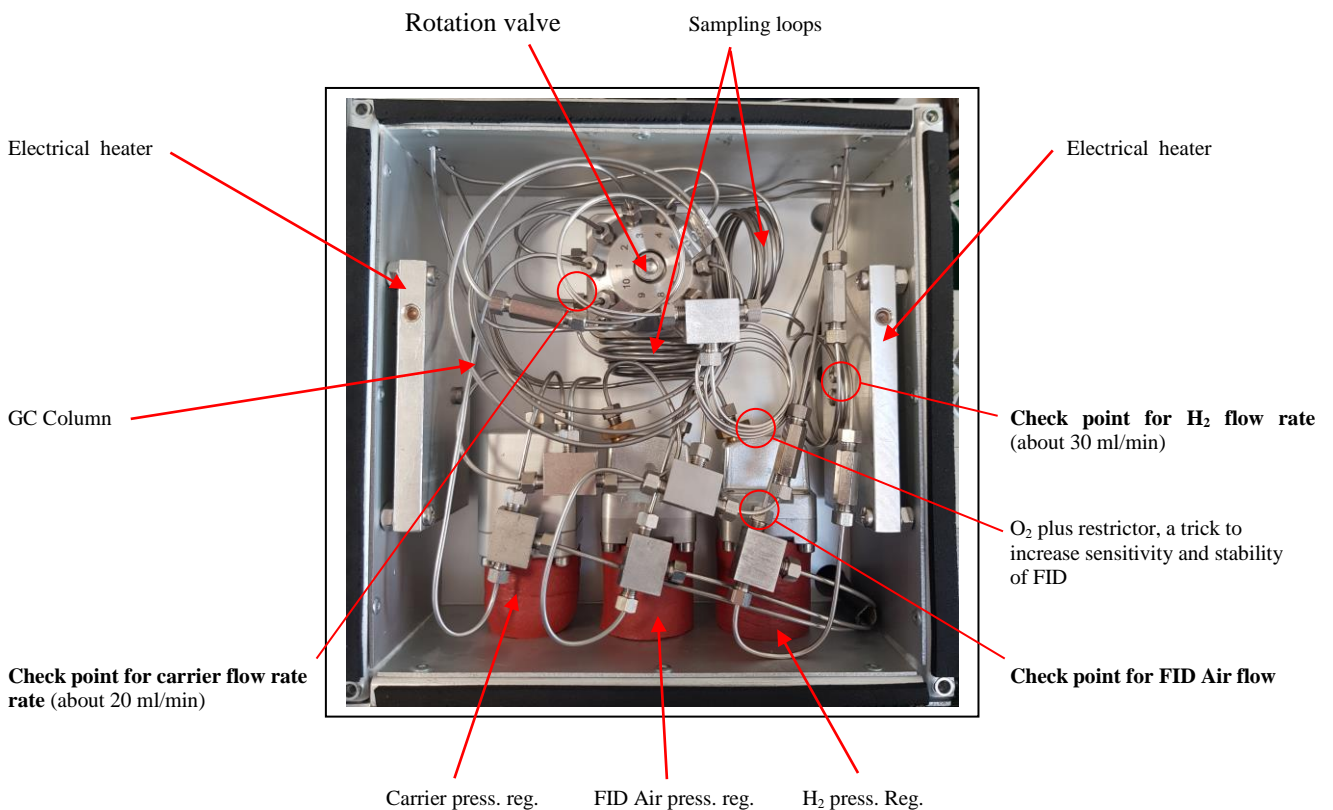

**NOTE:** for checking the flow rates do not disconnect the plumbing to the FID. It is very dangerous, if you spoil the tread you must replace the complete FID!!

### *FID AIR capillary check*

By employing an 8 mm spanner disconnect the 2 mm steel tube connected to FID detector through the "AIR" tagged input; then by a soap bubble flow meter and or by a digital flow meter check that flow rate corresponds to the value indicated in the final check table.

In case for the same air pressure the flow rate differs from the reported one in the check table restore the correct flow rate by varying the pressure of FID air operating on the relevant pressure regulator located on instrument front panel. If the correct flow rate cannot easily restored replace the capillary. When the check is completed connect back the steel tube to FID detector.

In the operation of connecting the steel tube to the FID detector a special care and attention must be given to the correct screwing of the connection in order to both avoid any damage to the thread as well as to have a tight connection.

The tightness of all connection are fundamental for a correct working condition of the instrument.

### *CARRIER flow rate check*

By employing an 8 mm spanner disconnect the 2 mm steel tube connected to FID detector through the "IN" tagged input; then by a soap bubble flow meter and/or by a digital flow meter check that flow rate corresponds to the value indicated in the final check table.

In case for the same air pressure the flow rate differs from the reported one in the check table restore the correct flow rate by varying the pressure of Carrier air operating on the relevant pressure regulator located on instrument front panel. If the correct flow rate cannot easily restored replace the capillary. When the check is completed connect back the steel tube to FID detector.

In the operation of connecting the steel tube to the FID detector a special care and attention must be given to the correct screwing of the connection in order to both avoid any damage to the thread as well as to have a tight connection.

The tightness of all connection are fundamental for a correct working condition of the instrument.

### *H<sub>2</sub> flow rate check*

By employing an 8 mm spanner disconnect the 2 mm steel tube connected to FID detector through the "H<sub>2</sub>" tagged input. Then turn in the right direction (clock wise) Px trimmer located on the mother board till the H<sub>2</sub> interception valve is active (take note of the turns required).

Then by a soap bubble flow meter and/or by a digital flow meter check that flow rate corresponds to the value indicated in the final check table.

In case for the same air pressure the flow rate differs from the reported one in the check table restore the correct flow rate by varying the hydrogen pressure operating on the relevant pressure regulator located on instrument front panel. If the correct flow rate cannot easily restored replace the capillary. When the check is completed connect back the steel tube to FID detector, rotate Px trimmer located on the mother board (see service manual) to left direction (anti clock wise) of the same turn number till the safety solenoid valve opens again.

In the operation of connecting the steel tube to the FID detector a special care and attention must be given to the correct screwing of the connection in order to both avoid any damage to the thread as well as to have a tight connection.

The tightness of all connection are fundamental for a correct working condition of the instrument.

## 11.2 SUGGESTED MAINTENANCE SCHEDULE

Basically, PCF's Mod. 529/NR, NMH (Non-Methane Hydrocarbon) analyser is a very simple process gas chromatograph with tested parts to last years without maintenance.

The ten-port valve, the most sophisticated part in the instrument, should last more than three years without maintenance.

For a good performance in the field it is suggested to commission the instrument since the beginning with the correct gas qualities and pressure as well as to check regularly its working conditions.

For a good commissioning and maintenance of the instrument we recommend:

- standard tool case
- digital multi meter
- digital flow meter and
- strip chart recorder (0-10 Vdc).

Time	Operations	Actions (if necessary)
Commissioning	Check: Quality of ZERO AIR Power Supply Gas Supplies (quality and pressure) Service Gas pressure Analogue outputs	
Monthly	Sample flow rates  Calibration check	Replace or clean filters Front filter Do a full calibration cycle
Every 3 months	Sample flow Membrane pump	Rebuild pump
Every year	Retention times Check: H <sub>2</sub> capillary Air capillary Carrier capillary Sampling pump	Adjust retention times  Replace
Every 2 years	Rotation valve	Maintain or replace

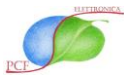

### 11.3 TROUBLE SHOOTING

For a correct operation of the instrument the following working conditions are mandatory:

- i) the correct pressure and quality of supplied gases
- ii) the correct flow rate of H<sub>2</sub>, Zero Air to FID, Carrier Air and Sample.

#### **Instrument completely dead:**

- |   |   |
|---|---|
| - Check the mains power supply              | Connect power supply                            |
| - Check the fuse on the power supply socket | Eventually replace the fuse on the power supply |
| - Mother Board is not working               | Replace Mother Board                            |

#### **The flame does not ignite**

- |   |  |
|---|--|
| - Mother Board is not working               | Replace Mother Board   |
| - Lack of Hydrogen or Air                   | Supply Hydrogen and Air<br><i>Please remember that at the installation the H<sub>2</sub> tubes may contain residual air. You MUST purge the air before the FID lights.</i> |
| - Ignition spiral is broken                 | Replace FID  |
| - Thermocouple is broken                    | Replace FID  |
| - Clogged H <sub>2</sub> or Air capillaries | Check flow rate and replace if necessary   |
| - Transformer not working                   | Replace transformer  |
| - Wrong hydrogen and air pressures          | Set the correct hydrogen and air pressures   |

#### **Auto zero does not perform**

- |                                  |                      |
|----------------------------------|----------------------|
| - Electrometer board not working | Replace electrometer |
| - Mother Board not working       | Replace Mother Board |
| - Key Board not working          | Replace key board    |

#### **Output signals dead**

- |                                   |                             |
|-----------------------------------|-----------------------------|
| - FID detector not working        | Replace FID detector        |
| - Electrometer board not working  | Replace electrometer board  |
| - Output signal board not working | Replace output signal board |
| - Mother board not working        | Replace Mother board        |

#### **4-20 mA signal not present**

- |                           |                             |
|---------------------------|-----------------------------|
| Check external connection | Restore external connection |
| 4-20 mA board not working | Replace 4-20 mA board       |

#### **Lack of Carrier gas pressure**

- |  |                                     |
|--|-------------------------------------|
| - Supply air cylinder either empty or with closed interception valve | Open the gas cylinder or replace it |
| - Leakage in the relevant circuit                                    | Find and mend the leakage           |
| - Pressure regulator not working                                     | Replace it                          |
| - Manometer not working  | Replace it                          |



### Lack of FID Air pressure

- |  |                                     |
|--|-------------------------------------|
| - Supply air cylinder either empty or with closed interception valve | Open the gas cylinder or replace it |
| - Leakage in the relevant circuit                                    | Find and mend the leakage           |
| - Pressure regulator not working                                     | Replace it                          |
| - Manometer not working  | Replace it                          |

### Auto zero function not operative

- |                                  |                            |
|----------------------------------|----------------------------|
| - Electrometer board not working | Replace electrometer board |
| - Mother Board not working       | Replace Mother Board       |
| - Key Board not working          | Replace key Board          |

### No variations on output signals

- |                                   |                             |
|-----------------------------------|-----------------------------|
| - FID detector not working        | Replace FID detector        |
| - Electrometer board not working  | Replace electrometer board  |
| - Output signal board not working | Replace output signal board |
| - Mother Board not working        | Replace Mother Board        |

### Missing 4-20 mA signal

- |   |                             |
|---|-----------------------------|
| - Check the external interconnection      | Restore the interconnection |
| - 4-20 mA output signal board not working | Replace it                  |

### No pressure on carrier gas

- |   |   |
|---|---|
| - Air gas cylinder either empty or closed | Open the air gas cylinder or replace it |
| - Leakage in the relevant circuit         | Amend the leakage                       |
| - Pressure regulator not working          | Replace pressure regulator              |
| - Manometer not working                   | Replace manometer                       |

### No pressure on FID Air

- |   |  |
|---|--|
| - Air gas cylinder either empty or closed | Either open the air gas cylinder or replace it |
| - Leakage in the inner pneumatic circuit  | Amend the leakage                              |
| - Pressure regulator not working          | Replace pressure regulator                     |
| - Manometer not working                   | Replace manometer                              |

### No hydrogen pressure

- |  |  |
|--|--|
| - Hydrogen gas cylinder either empty or closed | Either open the air gas cylinder or replace it |
| - Leakage in pneumatic circuit                 | Amend the leakage                              |
| - Pressure regulator not working               | Replace pressure regulator                     |
| - Intercepting solenoid valve not working      | Replace solenoid valve                         |
| - Mother Board not working                     | Replace Mother Board                           |
| - Manometer not working                        | Replace manometer                              |

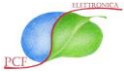

### No circulation of sample

- |  |  |
|--|--|
| - Addition sample line either intercepted or clogged | Restore correct sample flow                                    |
| - Membrane pump not working                          | Either replace or repair membrane pump                         |
| - Mother Board not working                           | Replace Mother Board   |
| - Rotation valves not working properly               | Replace rotation valves  |
| - Clogging in the analytical circuit                 | Find and amend the clogging cause and restore the correct flow |

### Low Methane peak on display (< 1.8 ppm)

- |   |   |
|---|---|
| Poor zero air quality, the high temperature scrubber does not scrub the whole methane content | Maintain the scrubber, if necessary change the zero air generator |
|---|---|

### Low calibration values

- |  |                             |
|--|-----------------------------|
| - New calibration procedure must be performed    | Carry out a new calibration |
| - Sampling loops partially clogged               | Replace sampling loops      |
| - Defective rotation valves                      | Replace rotation valves     |
| - Gas chromatographic column not active any more | Replace GC column           |

### No reproducible values

- |   |   |
|---|---|
| - Check quality of ZERO AIR<br>Feed FID AIR and CARRIER with the air from a certified gas cylinder and measure the quality of the air generated by a zero air generator as sample | - Maintain scrubber of zero air generator or if not enough reduce the quantity of air passed through zero air generator |
|---|---|

## 12.0 SERIAL COMMUNICATIONS AND ELECTRICAL CONNECTIONS

The new Mod. 529/NR foresees three types of serial communication: RS 232-345 and Ethernet/LAN.

All the serial communications operate both ways i.e. for the input as well for the output of the instrument.

The serial communication takes place in ASHI code at 9600 baud rate, no parity bit, 8 start bit 1 stop bit.

RS 232 serial output port connection scheme (11)

7 = GND

3 = RX

2 = TX

ELECTRICAL CONNECTIONS

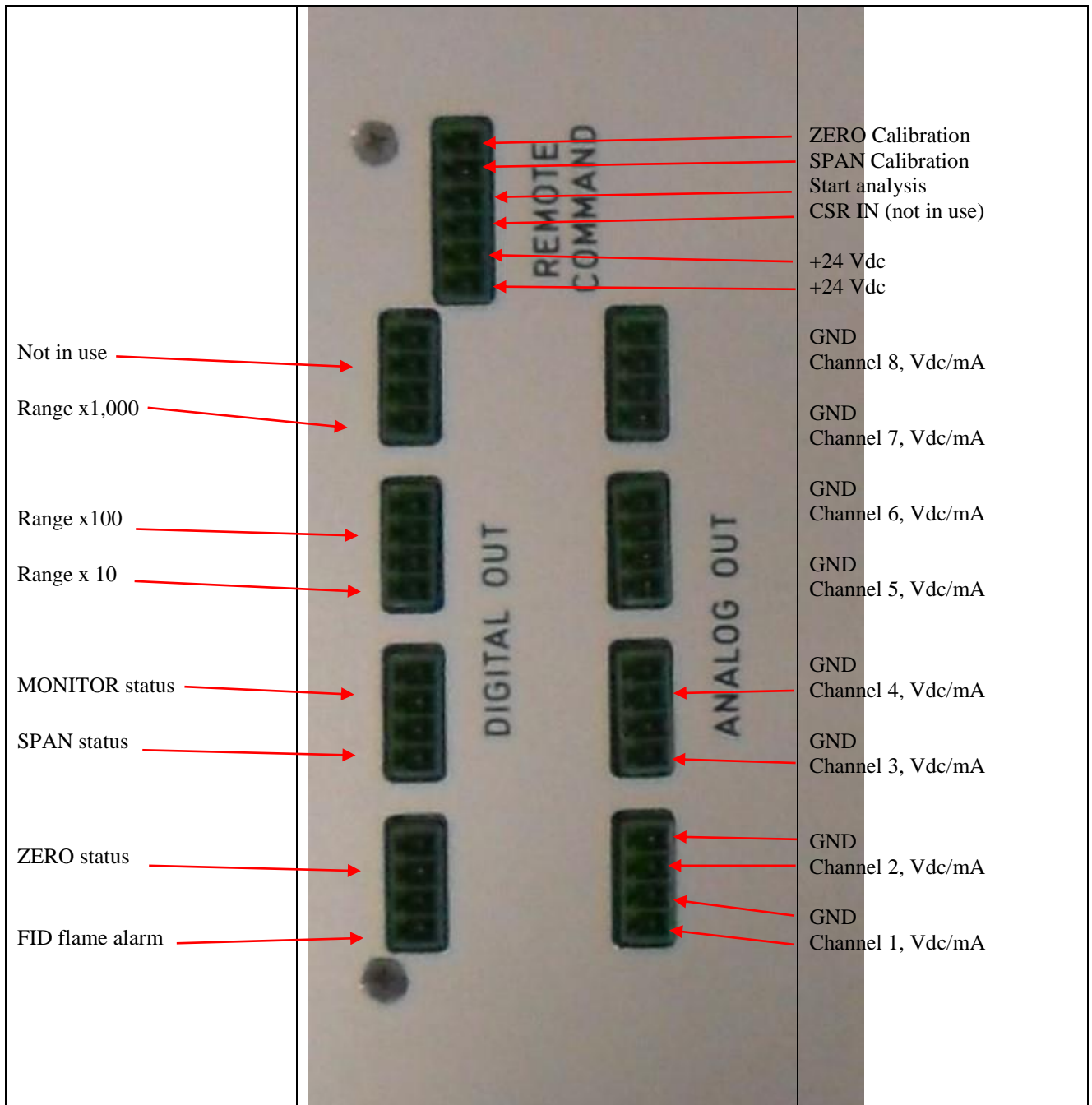

**NOTE:**

- 1- Clean contacts, normally CLOSED/OPEN according to the setting from the front panel.
- 2- Ranges:

Range x1 No contact closed	Range x 10 Relevant contact closed	Range x 100 Relevant contact closed	Range x1,000* Relevant contact closed	Range x10,000 Ranges x10+1,000 closed	Range x100,000 Ranges x100+1,000 closed
-------------------------------	---------------------------------------	--	--	--	--

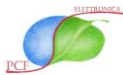

### 13.0 SPARE PART LIST

Code Number	Description
09520114	Sample capillary
09520115	Hydrogen capillary
09520116	Air capillary
09520120	Pressure regulator
09520121	Bar gauge
09520125	FID detector sub assembly
09520130	Red LED
09520131	Green LED
09520132	Return switch
09520133	Stable switch
09520134	SPAN potentiometer
09520135	Digital display
09520137	Power supply socket
09520138	Cooling fan
09520141	Electrometer PCB
09520147	4-20 mA outputs PCB
	Function programming, main PCB
	Auxiliary services PCB
09520145	Temperature regulator PCB
	+5 Vdc, +24 Vdc Stabilised Power Supply PCB
	+5 Vdc, $\pm 15$ Vdc Stabilised Power Supply PCB
09520150	PT 100 temperature gauge
09520152	FID detector heating resistance
09510116	Eight port Bimatic rotation valve
09510123	Rotation valve rebuild kit
09514822	Stainless steel tubing (10 m)
09514123	Seal set
09514124	Stainless steel pneumatic connections
09510112	SPAN solenoid valve
09514125	Fuse set
09510351	Sampling pump
09514126	Sampling pump rebuild kit
09510201	Hydrogen interception solenoid valve
09514127	Sintered filter
09510202	Rotation valve pilot solenoid valve
09514128	Flame ON temperature sensor
09514129	Flame ignition resistance
09514130	Mains switch
	Mother Board PCB
	IN/OUT Status PCB
09510336	Electrometer amplifier PCB
	Touch screen colour digital display
	GC column for NMH analysis



**Suggested consumables set (including)**

09520114	N.1 Sample/Carrier gas capillary
09510123	N.1 RSV rebuild kit
09514126	N.1 Sampling pump rebuild kit

**Suggested spare parts set (including)**

09520115	Hydrogen capillary
09520116	Air Capillary
09510943	N.1 Chromatographic column
09520120	N.1 Pressure regulator
09510115	N.1 Rotation valve

**The most frequently used pneumatic connections**

POS.	P/N	DESCRIPTION	PIC
1	062-6119	M12 Bolt with tightness	
2	100-0993	Ferrules for tube 2/1 (10 pcs x set)	
3	100-0992	6MB adapter for tube 2/1 (10 pcs set)	
4	100-6125	Linear conjunction for tubes 2/1	
5	100-6126	T-junction/adapter for tubes 2/1	
6	100-6127	2/1 tube to 6/4 tube adapter	
7	062-6302	Pieces of 2/1 tubes	

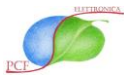

**PCF ELETTRONICA  
MOD. 529/NR NMH Analyzer  
AUTOMATIC GAS CHROMATOGRAPH**

Before shipment each instrument is thoroughly checked in our laboratories.  
Final reports are produced that accompany in copy the equipment.  
Please keep the documents with the original operating manual enclosed with the instrument.

**14.0 FINAL CHECK RECORDS**

Here below please find here an exempl of the final check cards delivered with and for each monitor.

**529/NR    Serial N# \_\_\_\_\_**

H <sub>2</sub>	Bar _____	ml/min _____
AIR	Bar _____	ml/min _____
CARRIER	Bar _____	ml/min _____

SAMPLE FLOW : \_\_\_\_\_ ml/min  
CAMERA OVEN : \_\_\_\_\_ °C

**CALIBRATION PARAMETERS**

Range:	Component :	
10	CH <sub>4</sub>	: ..... ppm : ..... ADJ (Kcal)
	TVOC/THC	: ..... ppm : ..... ADJ (Kcal)
	NMH	: ..... ppm : ..... ADJ (Kcal)

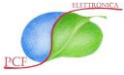

Range:	Component :		
20	CH <sub>4</sub>	: ..... ppm : ..... ADJ (Kcal)	
	TVOC/THC	: ..... ppm : ..... ADJ (Kcal)	
	NMH	: ..... ppm : ..... ADJ (Kcal)	
	50	CH <sub>4</sub>	: ..... ppm : ..... ADJ (Kcal)
		TVOC/THC	: ..... ppm : ..... ADJ (Kcal)
		NMH	: ..... ppm : ..... ADJ (Kcal)
100	CH <sub>4</sub>	: ..... ppm : ..... ADJ (Kcal) (Kcal)	
	TVOC/THC	: ..... ppm : ..... ADJ (Kcal)	
	NMH	: ..... ppm : ..... ADJ ((Kcal)	

Service Engineer: \_\_\_\_\_

Date: \_\_\_\_\_

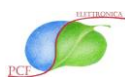

## **Appendix 1** - Extract of FID response factors for the most common organic components

Here below please find some of the experimentally obtained **FID responses**, wider evidence you may find in Internet:

[http://che.psu.edu/faculty/rioux/group/group\\_info/references/response\\_factors\\_for\\_gas\\_chromatographic\\_analyses.pdf](http://che.psu.edu/faculty/rioux/group/group_info/references/response_factors_for_gas_chromatographic_analyses.pdf)

<i>Organic Compound</i>	<i>Molecular Weight</i>	<i>Relative Sensitivity</i>	<i>Response Factor [1]</i>	<i>Response against Methane</i>	<i>Response against Propane</i>	<i>ppm to mg/m<sup>3</sup> conversion factor</i>	<i>ppm to mgC/m<sup>3</sup> conversion factor</i>
Methane	16.04303	0.99	15.8826	<b>1.0000</b>	0.3675	0.7158	0.5359
Ethane	30.07012	0.98	29.4687	1.8554	0.6819	1.3416	1.0718
Propane	44.09721	0.98	43.2153	2.7209	<b>1.0000</b>	1.9674	1.6076
Butane	58.12430	1.09	63.3555	3.9890	1.4660	2.5932	2.1435
Pentane	72.15139	1.04	75.0374	4.7245	1.7364	3.2190	2.6794
Hexane	86.17848	1.03	88.7638	5.5887	2.0540	3.8449	3.2153
Heptane	100.2056	1.00	100.2056	6.3091	2.3188	4.4707	3.7511
Octane	114.2327	0.97	110.8057	6.9765	2.5640	5.0965	4.2870
Nonane	128.2598	0.98	125.6946	7.9140	2.9086	5.7223	4.8229
Isopentane	72.15139	1.05	75.7590	4.7699	1.7531	3.2190	2.6794
2,2-dimethyl Butane	86.17848	1.04	89.6256	5.6430	2.0739	3.8449	3.2153
2,3-dimethyl Butane	86.17848	1.03	88.7638	5.5887	2.0540	3.8449	3.2153
2-methyl Pentane	86.17848	1.05	90.4874	5.6973	2.0939	3.8449	3.2153
3-methyl Pentane	86.17848	1.04	89.6256	5.6430	2.0739	3.8449	3.2153
2,2-dimethyl Pentane	100.2056	1.02	102.2097	6.4353	2.3651	4.4707	3.7511
2,3-dimethyl Pentane	100.2056	0.99	99.2035	6.2461	2.2956	4.4707	3.7511
1,1,2-trimethyl cycle hexane	126.2438	0.98	123.7189	7.7896	2.8629	5.6324	4.8229
Cycle heptane	98.18963	1.01	99.1715	6.2440	2.2948	4.3807	3.7511
Benzene	78.11472	1.12	87.4885	5.5084	2.0245	3.4851	3.2153
Toluene	92.14181	1.10	101.3560	6.3816	2.3454	4.1109	3.7511
Ethyl Benzene	106.1689	1.03	109.3540	6.8851	2.5304	4.7367	4.2870
Para Xylene	106.1689	1.00	106.1689	6.6846	2.4567	4.7367	4.2870
Meta Xylene	106.1689	1.04	110.4157	6.9520	2.5550	4.7367	4.2870
Ortho Xylene	106.1689	1.02	108.2923	6.8183	2.5059	4.7367	4.2870
1,2,3-trimethyl Benzene	120.1960	0.98	117.7921	7.4164	2.7257	5.3625	4.8229
N propyl Benzene	120.1960	1.01	121.3980	7.6435	2.8091	5.3625	4.8229
n- butyl Benzene	134.2231	0.98	131.5386	8.2819	3.0438	5.9884	5.3588
Acetylene	26.03824	1.07	27.8609	1.7542	0.6447	1.1617	1.0718
Ethylene	28.05418	1.02	28.6153	1.8017	0.6622	1.2516	1.0718
Methanol	32.04243	0.23	7.3698	0.4640	0.1705	1.4296	0.5359
Ethanol	46.06952	0.46	21.1920	1.3343	0.4904	2.0554	1.0718
n- Propanol	60.09661	0.60	36.0580	2.2703	0.8344	2.6812	1.6076
Iso propanol	60.09661	0.53	31.8512	2.0054	0.7370	2.6812	1.6076
n-Butanol	74.12370	0.66	48.9216	3.0802	1.1320	3.3070	2.1435
Iso butanolo	74.12370	0.68	50.4041	3.1735	1.1663	3.3070	2.1435
sec-Butano	74.12370	0.63	46.6979	2.9402	1.0806	3.3070	2.1435

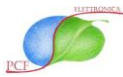

ter-Butanol	74.12370	0.74	54.8515	3.4536	1.2693	3.3070	2.1435
Methyl-iso-buthyl-carbinol	88.15079	0.74	65.2316	4.1071	1.5095	3.9328	2.6794
1-Hexanol	102.17790	0.74	75.6116	4.7607	1.7496	4.5587	3.2153
1-Octanol	128.21610	0.85	108.9837	6.8618	2.5219	5.7204	4.2870
1-Decanol	154.25440	0.84	129.5737	8.1582	2.9983	6.8821	5.3588
Butyrraldehyde	72.10776	0.62	44.7068	2.8148	1.0345	3.2171	2.1435
1-Eptaldehyde	114.18900	0.77	87.9255	5.5360	2.0346	5.0945	3.7511
1-Octaldehyde	128.21610	0.80	102.5729	6.4582	2.3735	5.7204	4.2870
Decanal	156.27030	0.80	125.0162	7.8713	2.8929	6.9720	5.3588
Formic acid	46.02589	0.01	0.4603	0.0290	0.0107	2.0534	0.5359
Acetic acid	60.08807	0.23	13.8122	0.8696	0.3196	2.6793	1.0718
NMH portable GC8							
Propionic acid	74.08007	0.40	29.6320	1.8657	0.6857	3.3051	1.6076
Butyric acid	88.10716	0.48	42.2914	2.6628	0.9786	3.9309	2.1435
Hexanoic acid	116.16130	0.63	73.1816	4.6077	1.6934	5.1825	3.2153
Eptanoic acid	130.18840	0.61	79.4149	5.0001	1.8377	5.8084	3.7511
Octanoic acid	144.21550	0.65	93.7401	5.9021	2.1691	6.4342	4.2870
Methyl acetate	74.08007	0.20	14.8160	0.9328	0.3428	3.3051	1.6076
Ethyl acetate	88.10716	0.38	33.4807	2.1080	0.7747	3.9309	2.1435
Isopropyl acetate	102.13430	0.49	50.0458	3.1510	1.1581	4.5567	2.6794
sec-Buthyl-acetate	116.16130	0.52	60.4039	3.8031	1.3977	5.1825	3.2153
Iso-buthyl acetate	116.16130	0.54	62.7271	3.9494	1.4515	5.1825	3.2153
Acetonitrile	41.08807	0.39	16.0106	1.0081	0.3705	1.8316	1.0718
NMH portable GC1							
Dimethyl formamide	73.09534	0.41	29.9691	1.8869	0.6935	3.2611	1.6076
Trimethyl amine	59.11188	0.46	27.1915	1.7120	0.6292	2.6373	1.6076
Ter-Buthyl amine	73.13897	0.54	39.4950	2.4867	0.9139	3.2631	2.1435
Diethyl amine	73.13897	0.61	44.6148	2.8090	1.0324	3.2631	1.0718
Aniline	93.12939	0.75	69.8470	4.3977	1.6163	4.1550	3.2153
Acetone	58.08067	0.59	34.2676	2.1576	0.7930	2.5913	1.6076
Tetrahydrofuran	72.10776	0.76	54.8019	3.4504	1.2681	3.2171	2.1435
Isopropyl ether	102.17790	0.70	71.5245	4.5033	1.6551	4.5587	3.2153
2-Butoxyethanolo	118.17730	0.60	70.9064	4.4644	1.6408	5.2725	3.2153

[1] – response factor = relative sensitivity x molecular weight.



## Appendix 2

### **A.2.1 HYDROGEN SAFETY (very important!)**

The combustible gas (H<sub>2</sub>) supplied to the instrument must show a 99,999% (in volume) purity.  
The highest allowed concentration (impurity) of VOC in it **must not override 0.1 mg/m<sup>3</sup>**.

Our Company suggests and supplies, when requested to, 5.5 “Transistor” type Hydrogen,

- purity 99,9995% ,gas chromatographic purity
- H<sub>2</sub>O content < 3 ppmV
- O<sub>2</sub> content < 1 ppm

PLEASE DO NOT SUPPLY H<sub>2</sub> AT A PRESSURE HIGHER THAN THE SUGGESTED ONE:  
H<sub>2</sub>= 3,0 Bar max.

The care that all the requirements foreseen for the safe use of combustible gases lies with customer’s responsibility.

Cautions when using hydrogen

The Customer must take care that all the hydrogen gas cylinders be according the actual safety norms and requirements, as well as take care of the lodging rooms, of the installation of safety valves that interrupt the hydrogen flow automatically in case of alarm condition, etc.

## Appendix 3

### **A.3.1 Entering the SERVICE MENU (very delicate matter!)**

Usually the field operator deals with the HOME Menu.

If it is necessary to enter (very delicate matter!!) the Service Menu please consult the Factory.

### **A.3.2 Resetting the touch screen**

It could happen that you need to rest the touch screen.

If necessary contact the PCF’s Service Dept.

### **A.3.3 Sucking capacity of air ejector**